

Retro-Fit Manual v1.2

Chemetron Analog Alarm



Product Specifications

The Amico Retro-fit Alarm will allow an existing Chemetron/Allied alarm to be replaced, without moving the existing back box and pipe-stubs.

The LCD filler frame enables the Amico Alert-3 LCD alarm front assembly to sit on the wall of the existing alarm panel box. The filler frame acts like a spacer between the Chemetron/Allied box and the front assembly. Please make sure that the power source at the breaker panel is turned off before replacing the power supply. The gas supply may also be required to be shut off.

Installation Instructions

The filler frame acts like a spacer between the Chemetron box and the front assembly. Please make sure that the gas is turned off before the retro-fit alarm is installed.



Remove the front frame and the display module from the back box. When removing the display module you have to remove the sensor connection to the pipe stub.



Remove all internal components of the Chemetron Alarm (mother board, power supply, sensors and all wiring).



Ensure that the back box is clear of all screws, studs, stand-offs and insert tabs. Bend the lower front lip of the alarm box. Ensure that the lip is flat. Add the chrome sensor fitting that is factory supplied, and that is attached to each sensor.



Add the power supply to the far left corner of the back box assembly. Use 4 tapping screws to hold the power supply into the box. Use tapping screws for grounding wires. Please note that tapping screws, or any other screws, are not supplied by Amico.



Plug in the Amico sensor with the gas label facing you.

Add the Amico filler box to the wall surface. Ensure that the box on the wall is at the center of the filler box.

Remove the Amico front frame from the divider plate. First, attach the LCD filler plate hinge, then attach the LCD filler plate wire to the filler box.

Screw the LCD filler plate to the filler box and attach the front LCD filler frame.

Installation Instructions

A complete alarm assembly conversion from Chemetron to Amico.

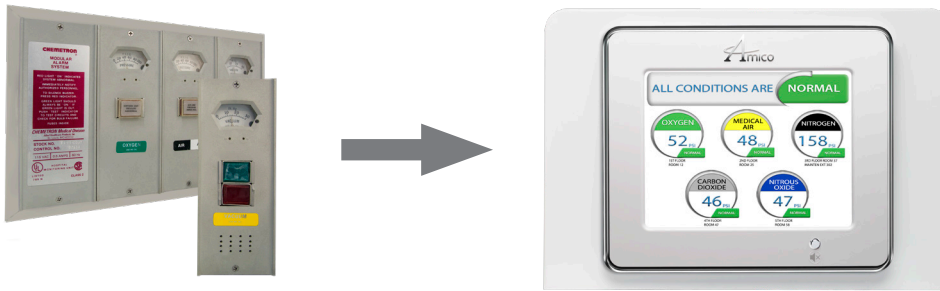

Product Dimensions

Front View

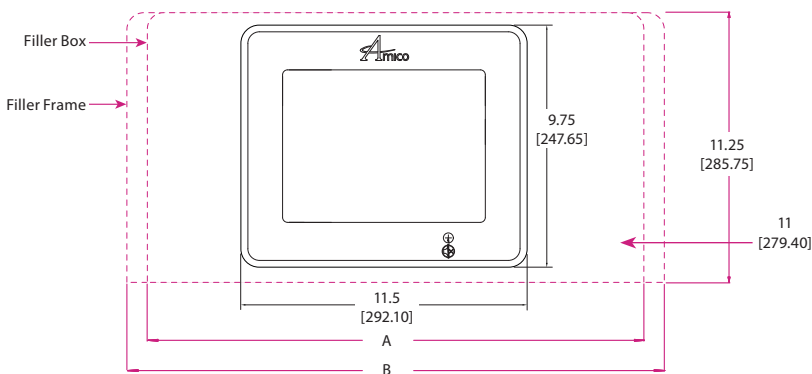

Top View

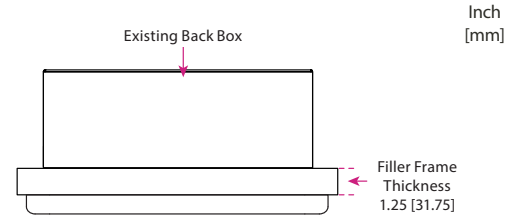

Side View

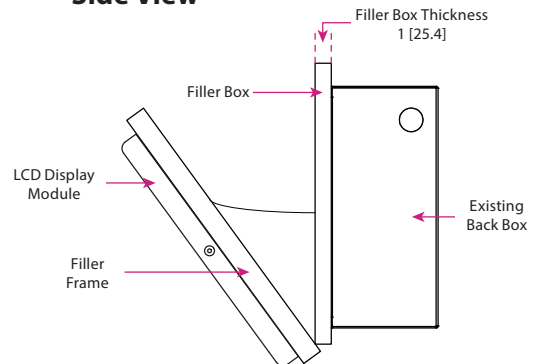

| Number of Display Modules (existing) | A (Filler Box) | B (Filler Frame) | Number of Gangs | Trim Plate Height |
|--------------------------------------|----------------|------------------|-----------------|-------------------|
| From 1 to 2 modules | 12.75 (324) | N/A | 3 | 2.125 (54) |
| From 1 to 3 modules | 16 (406) | 16.25 (413) | 4 | 2.125 (54) |
| From 1 to 4 modules | 19.3 (490) | 19.56 (497) | 5 | 2.125 (54) |
| From 1 to 6 modules | 26 (660) | 26.25 (667) | 7 | 2.125 (54) |

NOTES:

Standard height for the Trim Plate is 2.125" (54 mm) and the width is the same as Column A (Filler Box)

Filler Frame Part Numbers

| | |
|------------------|---|
| A3P-LCD-FILLER-3 | Alert-3 LCD Conversion Alarm Filler Frame 3-Station |
| A3P-LCD-FILLER-4 | Alert-3 LCD Conversion Alarm Filler Frame 4-Station |
| A3P-LCD-FILLER-5 | Alert-3 LCD Conversion Alarm Filler Frame 5-Station |
| A3P-LCD-FILLER-7 | Alert-3 LCD Conversion Alarm Filler Frame 7-Station |

Trim Plates

| |
|-------------------|
| A3P-CONKIT-GANG-3 |
| A3P-CONKIT-GANG-4 |
| A3P-CONKIT-GANG-5 |
| A3P-CONKIT-GANG-7 |

NOTES:

- Alert-2 Sensor Modules are not compatible with the Alert-3 LCD Alarm.
- An LCD filler frame is required if the existing alarm width is more than 10" (254 mm).

www.amico.com

Amico Corporation | 85 Fulton Way, Richmond Hill, ON L4B 2N4, Canada
71 East Industry Court, Deer Park, NY 11729, USA
Toll Free Tel: 1.877.462.6426 | Tel: 905.764.0800 | Fax: 905.764.0862
Email: info@amico.com | www.amico.com